

























CIC 200™ HEX SOCKET CAP SCREW ASSORTMENT

P/N 7700

FEATURES:

- Protected with black oxide coating
- Deep socket assures full wrench engagement
- Triple heat-treated alloy steel
- Minimum 180,000 PSI tensile strength
- Meets ASME/ANSI B18.3 requirements
- Class 3A precision rolled threads

330

 6-32 x 1/4 P/N 35520	 6-32 x 3/4 P/N 35540	 8-32 x 1/2 P/N 35565	 10-32 x 1/2 P/N 36601	 10-24 x 1/2 P/N 35601	 10-32 x 1-1/4 P/N 36606
 6-32 x 3/8 P/N 35525	 6-32 x 1 P/N 35550	 8-32 x 5/8 P/N 35570	 10-32 x 5/8 P/N 36602	 10-24 x 5/8 P/N 35602	 10-32 x 1-1/2 P/N 36607
 6-32 x 1/2 P/N 35530	 8-32 x 1/4 P/N 35555	 8-32 x 3/4 P/N 35575	 10-32 x 3/4 P/N 36603	 10-24 x 3/4 P/N 35603	 10-24 x 1-1/4 P/N 35606
 6-32 x 5/8 P/N 35535	 8-32 x 3/8 P/N 35560	 8-32 x 1 P/N 35585	 10-32 x 1 P/N 36605	 10-24 x 1 P/N 35605	 10-24 x 1-1/2 P/N 35607

A12-1

TRAY FRONT



CIC 200™ SOCKET SET SCREWS

































P/N 7704

NOTE: Part numbers in bold italic are **NOT** available with knurled cup point.

FEATURES:

- Deep socket provides stronger hex key engagement
- Black oxide for durability and corrosion resistance
- Class 3A precision rolled threads meets ASME/ANSI B18.3
- Special internal knurled cup point provides superior holding power
- Rockwell "C" hardness 45-53

500

 4-40 x 1/8 P/N 2225	 6-32 x 1/8 P/N 2235	 8-32 x 1/8 P/N 2250	 10-24 x 3/16 P/N 2265	 10-32 x 3/16 P/N 5265	 1/4-20 x 1/4 P/N 2281	 5/16-18 x 5/16 P/N 2292	 3/8-16 x 1/2 P/N 2309
 4-40 x 3/16 P/N 2226	 6-32 x 3/16 P/N 2236	 8-32 x 3/16 P/N 2251	 10-24 x 1/4 P/N 2266	 10-32 x 1/4 P/N 5266	 1/4-20 x 5/16 P/N 2282	 5/16-18 x 3/8 P/N 2293	 7/16-14 x 1/2 P/N 2322
 4-40 x 1/4 P/N 2227	 6-32 x 1/4 P/N 2237	 8-32 x 1/4 P/N 2252	 10-24 x 3/8 P/N 2268	 10-32 x 3/8 P/N 5268	 1/4-20 x 3/8 P/N 2283	 5/16-18 x 1/2 P/N 2295	 1/2-13 x 1/2 P/N 2331
 4-40 x 3/8 P/N 2229	 6-32 x 3/8 P/N 2239	 8-32 x 3/8 P/N 2254	 10-24 x 1/2 P/N 2270	 10-32 x 1/2 P/N 5270	 1/4-20 x 1/2 P/N 2285	 3/8-16 x 3/8 P/N 2307	 1/2-13 x 1 P/N 2334

TRAY FRONT

A122















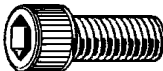









CIC 200™ HEX SOCKET CAP SCREW ASSORTMENT 6-32 to 3/8-16 P/N 17745

FEATURES:

- Protected with durable zinc chromate plating
- Deep socket assures full wrench engagement
- Triple heat-treated alloy steel
- Minimum 180,000 PSI tensile strength
- Meets ASME/ANSI B18.3 requirements
- Class 3A precision rolled threads

300

 6-32 x 3/8 P/N 35525	 8-32 x 3/8 P/N 35560	 10-24 x 1/2 P/N 35601	 1/4-20 x 1/2 P/N 35611	 5/16-18 x 1/2 P/N 35625	 3/8-16 x 3/4 P/N 35652
 6-32 x 1/2 P/N 35530	 8-32 x 1/2 P/N 35565	 10-24 x 5/8 P/N 35602	 1/4-20 x 3/4 P/N 35613	 5/16-18 x 3/4 P/N 35627	 3/8-16 x 1 P/N 35654
 6-32 x 5/8 P/N 35535	 8-32 x 5/8 P/N 35570	 10-24 x 3/4 P/N 35603	 1/4-20 x 1 P/N 35615	 5/16-18 x 1 P/N 35629	 3/8-16 x 1-1/4 P/N 35655
 6-32 x 3/4 P/N 35540	 8-32 x 3/4 P/N 35575	 10-24 x 1 P/N 35605	 1/4-20 x 1-1/4 P/N 35616	 5/16-18 x 1-1/2 P/N 35631	 3/8-16 x 1-1/2 P/N 35656

A12-3

TRAY FRONT



























CIC 200™ BUTTON HEAD SOCKET CAP SCREWS (4-40 to 10-32) P/N 17787

FEATURES:

- Deep socket provides stronger hex key engagement
- Excellent elongation properties for ultimate clamp load
- Black oxide finish for durability and corrosion resistance
- Smooth, chamfered end assures easy threading
- Class 3A precision rolled threads meets ASME/ANSI B18.3

545

 4-40 x 1/4 P/N 3901	 4-40 x 3/8 P/N 3902	 4-40 x 1/2 P/N 3903	 6-32 x 1/4 P/N 3906	 6-32 x 3/8 P/N 3907	 6-32 x 1/2 P/N 3908
 6-32 x 5/8 P/N 3909	 8-32 x 1/4 P/N 3911	 8-32 x 3/8 P/N 3912	 8-32 x 1/2 P/N 3913	 8-32 x 5/8 P/N 3914	 8-32 x 3/4 P/N 3915
 10-24 x 1/4 P/N 3918	 10-24 x 3/8 P/N 3919	 10-24 x 1/2 P/N 3920	 10-24 x 5/8 P/N 3921	 10-24 x 3/4 P/N 3922	 10-24 x 1 P/N 3923
 10-32 x 1/4 P/N 4918	 10-32 x 3/8 P/N 4919	 10-32 x 1/2 P/N 4920	 10-32 x 5/8 P/N 4921	 10-32 x 3/4 P/N 4922	 10-32 x 1 P/N 4923

A124

TRAY FRONT













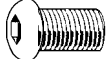
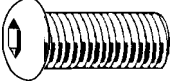

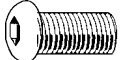

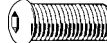
CIC 200™ BUTTON HEAD SOCKET CAP SCREWS (1/4-20 to 1/2-13) P/N 17788

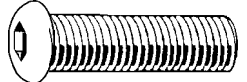
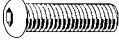
FEATURES:

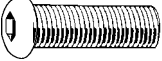
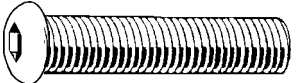
- Deep socket provides stronger hex key engagement
- Excellent elongation properties for ultimate clamp load
- Black oxide finish for durability and corrosion resistance
- Smooth, chamfered end assures easy threading
- Class 3A precision rolled threads meets ASME/ANSI B18.3

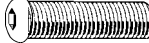
205

 1/4-20 x 3/8 P/N 3926	 5/16-18 x 3/8 P/N 3932	 3/8-16 x 1/2 P/N 3938	 1/2-13 x 1 P/N 3945
 1/4-20 x 1/2 P/N 3927	 5/16-18 x 1/2 P/N 3933	 3/8-16 x 5/8 P/N 3939	
 1/4-20 x 5/8 P/N 3928	 5/16-18 x 5/8 P/N 3934	 3/8-16 x 3/4 P/N 3940	 1/2-13 x 1-1/2 P/N 3947
 1/4-20 x 3/4 P/N 3929	 5/16-18 x 3/4 P/N 3935	 3/8-16 x 1 P/N 3941	 1/2-13 x 2 P/N 3948
 1/4-20 x 1 P/N 3930	 5/16-18 x 1 P/N 3936	 3/8-16 x 1-1/4 P/N 3942	

A125

TRAY FRONT



























CIC 200™ LOW HEAD SOCKET CAP SCREWS

P/N 17809

FEATURES:

- Use where standard height socket head cap screws are too high and for applications with limited clearance
- RC Hardness 38-43
- 170,000 psi minimum tensile strength
- Precision Class 3A threads

375

 8-32 x 3/8 P/N 63400 Hex Key: 5/64	 8-32 x 1/2 P/N 63401 Hex Key: 5/64	 8-32 x 3/4 P/N 63402 Hex Key: 5/64	 8-32 x 1 P/N 63403 Hex Key: 5/64	 10-24 x 3/8 P/N 63404 Hex Key: 3/32	 10-24 x 1/2 P/N 63405 Hex Key: 3/32
 10-24 x 3/4 P/N 63406 Hex Key: 3/32	 10-32 x 3/8 P/N 63407 Hex Key: 3/32	 10-32 x 1/2 P/N 63408 Hex Key: 3/32	 10-32 x 5/8 P/N 63409 Hex Key: 3/32	 10-32 x 3/4 P/N 63410 Hex Key: 3/32	 1/4-20 x 3/8 P/N 63411 Hex Key: 1/8
 1/4-20 x 1/2 P/N 63412 Hex Key: 1/8	 1/4-20 x 5/8 P/N 63413 Hex Key: 1/8	 1/4-20 x 3/4 P/N 63414 Hex Key: 1/8	 1/4-20 x 1 P/N 63415 Hex Key: 1/8	 5/16-18 x 1/2 P/N 63416 Hex Key: 5/32	 5/16-18 x 3/4 P/N 63417 Hex Key: 5/32
 5/16-18 x 1 P/N 63418 Hex Key: 5/32	 5/16-18 x 1-1/2 P/N 63420 Hex Key: 5/32	 3/8-16 x 1/2 P/N 63421 Hex Key: 3/16	 3/8-16 x 3/4 P/N 63422 Hex Key: 3/16	 3/8-16 x 1 P/N 63423 Hex Key: 3/16	 3/8-16 x 1-1/2 P/N 63425 Hex Key: 3/16

A126

TRAY FRONT

























CIC 150™ FLAT HEAD SOCKET CAP SCREWS (4-40 to 10-32)

P/N 17824

FEATURES:

- Deep socket provides stronger hex key engagement
- Smooth, chamfered end assures easy threading
- Minimum 160,000 psi tensile strength
- Class 3A precision threads meet ASME/ANSI B18.3
- Triple heat-treated alloy steel for durability and corrosion resistance

855

 4-40 x 1/4 P/N 61700	 4-40 x 3/8 P/N 61701	 4-40 x 1/2 P/N 61702	 4-40 x 5/8 P/N 61703	 4-40 x 3/4 P/N 61704	 6-32 x 1/4 P/N 61710
 6-32 x 3/8 P/N 61711	 6-32 x 1/2 P/N 61712	 6-32 x 5/8 P/N 61713	 6-32 x 3/4 P/N 61714	 8-32 x 3/8 P/N 61715	 8-32 x 1/2 P/N 61716
 8-32 x 5/8 P/N 61717	 8-32 x 3/4 P/N 61718	 8-32 x 1 P/N 61719	 10-24 x 3/8 P/N 61720	 10-24 x 1/2 P/N 61721	 10-24 x 3/4 P/N 61723
 10-24 x 1 P/N 61724	 10-32 x 3/8 P/N 61727	 10-32 x 1/2 P/N 61728	 10-32 x 3/4 P/N 61730	 10-32 x 1 P/N 61731	

A127

TRAY FRONT















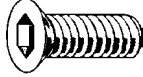
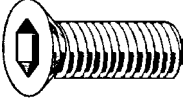

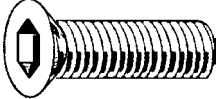

CIC 150™ FLAT HEAD SOCKET CAP SCREWS (1/4-20 to 1/2-13)

P/N 17825

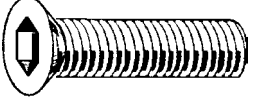
FEATURES:

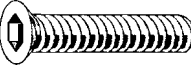
- Deep socket provides stronger hex key engagement
- Smooth, chamfered end assures easy threading
- Minimum 160,000 psi tensile strength
- Class 3A precision threads meet ASME/ANSI B18.3
- Triple heat-treated alloy steel for durability and corrosion resistance

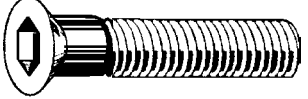
300

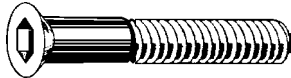
 1/4-20 x 1/2 P/N 61735	 5/16-18 x 1/2 P/N 61750	 3/8-16 x 3/4 P/N 61768	 1/2-13 x 1 P/N 61789
 1/4-20 x 3/4 P/N 61737	 5/16-18 x 3/4 P/N 61752	 3/8-16 x 1 P/N 61769	 1/2-13 x 1-1/4 P/N 61790
 1/4-20 x 1 P/N 61738	 5/16-18 x 1 P/N 61753	 3/8-16 x 1-1/4 P/N 61770	 1/2-13 x 1-1/2 P/N 61791
 1/4-20 x 1-1/4 P/N 61739	 5/16-18 x 1-1/4 P/N 61754	 3/8-16 x 1-1/2 P/N 61771	 1/2-13 x 2 P/N 61793
 1/4-20 x 1-1/2 P/N 61740	 5/16-18 x 1-1/2 P/N 61755	 3/8-16 x 2 P/N 61773	

A128

TRAY FRONT



























CIC 150™ BUTTON HEAD SOCKET CAP SCREWS (4-40 to 10-32)

P/N 17826

FEATURES:

- Deep socket provides stronger hex key engagement
- Smooth, chamfered end assures easy threading
- Class 3A precision threads meet ASME/ANSI B18.3
- Triple heat-treated alloy steel for durability and corrosion resistance
- Minimum 160,000 psi tensile strength

910

 4-40 x 1/4 P/N 61900	 4-40 x 3/8 P/N 61901	 4-40 x 1/2 P/N 61902	 6-32 x 1/4 P/N 61903	 6-32 x 3/8 P/N 61904	 6-32 x 1/2 P/N 61905
 6-32 x 5/8 P/N 61906	 8-32 x 1/4 P/N 61907	 8-32 x 3/8 P/N 61908	 8-32 x 1/2 P/N 61909	 8-32 x 5/8 P/N 61910	 8-32 x 3/4 P/N 61911
 10-24 x 1/4 P/N 61912	 10-24 x 3/8 P/N 61913	 10-24 x 1/2 P/N 61914	 10-24 x 5/8 P/N 61915	 10-24 x 3/4 P/N 61916	 10-24 x 1 P/N 61918
 10-32 x 1/4 P/N 61919	 10-32 x 3/8 P/N 61920	 10-32 x 1/2 P/N 61921	 10-32 x 5/8 P/N 61922	 10-32 x 3/4 P/N 61923	 10-32 x 1 P/N 61925

A129

TRAY FRONT















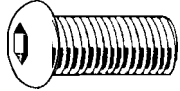

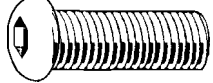

CIC 150™ BUTTON HEAD SOCKET CAP SCREWS (1/4-20 to 1/2-13)

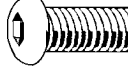
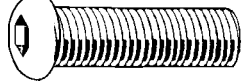
P/N 17827

FEATURES:

- Deep socket provides stronger hex key engagement
- Smooth, chamfered end assures easy threading
- Class 3A precision threads meet ASME/ANSI B18.3
- Triple heat-treated alloy steel for durability and corrosion resistance
- Minimum 160,000 psi tensile strength

410

 1/4-20 x 3/8 P/N 61926	 5/16-18 x 3/8 P/N 61937	 3/8-16 x 1/2 P/N 61948	 1/2-13 x 1 P/N 61958
 1/4-20 x 1/2 P/N 61927	 5/16-18 x 1/2 P/N 61938	 3/8-16 x 5/8 P/N 61949	 1/2-13 x 1-1/4 P/N 61959
 1/4-20 x 5/8 P/N 61928	 5/16-18 x 5/8 P/N 61939	 3/8-16 x 3/4 P/N 61950	 1/2-13 x 1-1/2 P/N 61960
 1/4-20 x 3/4 P/N 61929	 5/16-18 x 3/4 P/N 61940	 3/8-16 x 1 P/N 61952	 1/2-13 x 2 P/N 61961
 1/4-20 x 1 P/N 61931	 5/16-18 x 1 P/N 61942	 3/8-16 x 1-1/4 P/N 61953	

A12-10

TRAY FRONT

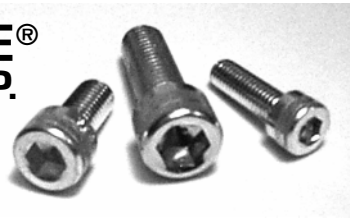

























CIC 150 SOCKET HEAD CAP SCREWS

P/N 17830

FEATURES:

- Thermal black oxide finish for durability and corrosion resistance
 - Heat-treated, high-strength alloy steel with deep socket for full wrench engagement
 - Smooth, chamfered end assures easy threading
 - Minimum 180,000* psi tensile strength
- *180,000 psi min 1/8" and smaller;
170,000 psi min 5/8" and larger.

600

 6-32 x 3/8 P/N 61106	 6-32 x 1/2 P/N 61107	 6-32 x 5/8 P/N 61108	 6-32 x 3/4 P/N 61109	 8-32 x 3/8 P/N 61113	 8-32 x 1/2 P/N 61114
 8-32 x 5/8 P/N 61115	 8-32 x 3/4 P/N 61116	 10-24 x 1/2 P/N 61122	 10-24 x 5/8 P/N 61123	 10-24 x 3/4 P/N 61124	 10-24 x 1 P/N 61126
 1/4-20 x 1/2 P/N 61131	 1/4-20 x 3/4 P/N 61133	 1/4-20 x 1 P/N 61134	 1/4-20 x 1-1/4 P/N 61135	 5/16-18 x 1/2 P/N 61141	 5/16-18 x 3/4 P/N 61143
 5/16-18 x 1 P/N 61144	 5/16-18 x 1-1/2 P/N 61146	 3/8-16 x 3/4 P/N 61153	 3/8-16 x 1 P/N 61154	 3/8-16 x 1-1/4 P/N 61155	 3/8-16 x 1-1/2 P/N 61156

TRAY FRONT

A12-11



CIC 200 HEX SOCKET WRENCH ASSORTMENT





P/N 17837

FEATURES:

- Chamfer ends eliminate burr problems
- Manufactured from the highest quality tool steel for strength and durability
- Exclusive corrosion resistant dry finish

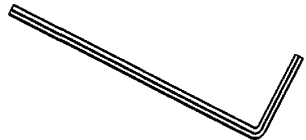
41

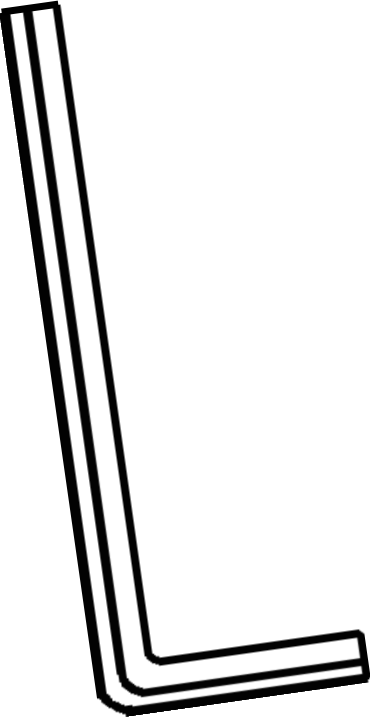
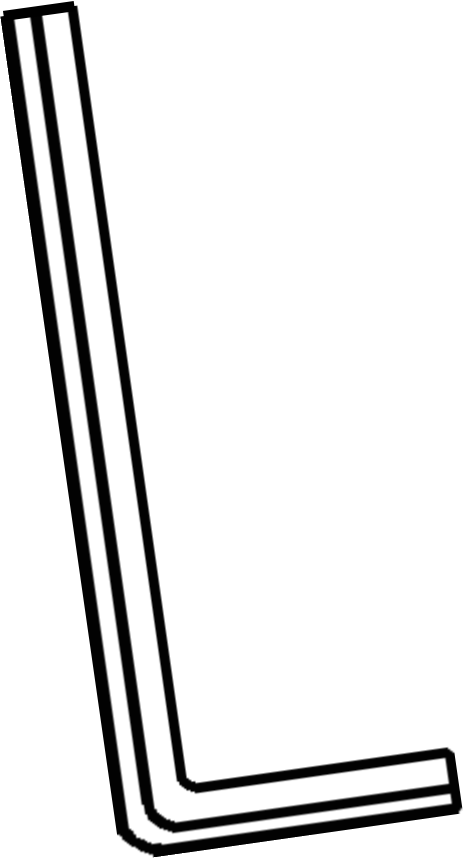
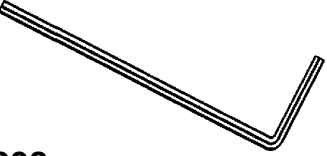
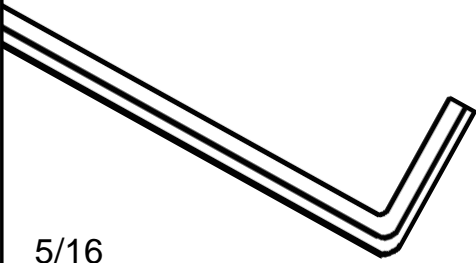
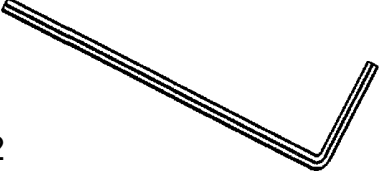
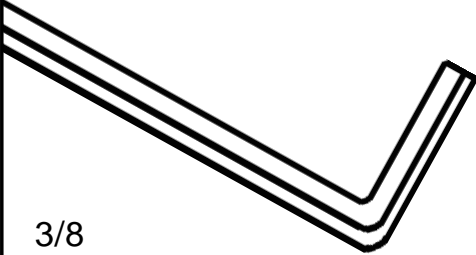
A12-12

<p>7/64 P/N 70206</p> 	<p>1/4 P/N 70212</p> 	 <p>1/2 P/N 70216</p>	 <p>5/8 P/N 70218</p>
<p>9/64 P/N 70208</p> 	<p>5/16 P/N 70213</p> 		
<p>5/32 P/N 70209</p> 	<p>3/8 P/N 70214</p> 		
<p>3/16 P/N 70210</p> 			

TRAY FRONT



CIC 200 SHOULDER SCREW ASSORTMENT













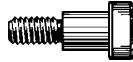

P/N 17839

FEATURES:

- Deep socket for full wrench engagement
- Heat-treated alloy steel
- Rockwell "C" hardness 45-53
- Unified 3A precision rolled thread fit meets ASME/ANSI B18.3
- Polished shoulder for smooth, precision fit

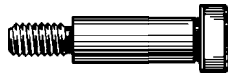
65

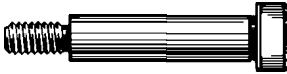
A12-13

 1/4 x 3/8 P/N 3602	 1/4 x 1/2 P/N 3603	 1/4 x 3/4 P/N 3605	 1/4 x 1 P/N 3606
 1/4 x 1-1/4 P/N 3607	 1/4 x 1-1/2 P/N 3608	 5/16 x 3/8 P/N 3610	 5/16 x 1/2 P/N 3611
 5/16 x 3/4 P/N 3613	 5/16 x 1 P/N 3614	 5/16 x 1-1/2 P/N 3616	 3/8 x 1 P/N 3624
 3/8 x 1-1/4 P/N 3625	 3/8 x 1-1/2 P/N 3626	 3/8 x 2 P/N 3628	 3/8 x 2-1/2 P/N 3630

TRAY FRONT